

Load cells specially designed for on-board weighing on trucks.



Model 2645 - 10 t



Features

- o Very sturdy design
- o High resistance against shocks
- o Protection class: IP67
- o Low-cost solution
- o Material: alloy steel
- o Easy to install (no stabilisation system needed)
- o Screws and blocks to be welded available
- o Cable length: see drawing table - CL (other lengths available on request)

Most popular options



Ex i



Application(s)

SENSY's load cells 2625-2645 are perfectly designed for the following applications:

- 'On-board' weighing system on trucks, lorries or agricultural trailers,
- 'On-board' overload preventing system,
- Railways weighing.

Capacities

2625: 10 t

2645: 10 - 50 t

Specifications	0.5 %	
Repeatability error	< ± 0.25	% F.S.*
Creep error over 30 min.	< ± 0.2	% F.S.*
Reference temperature	23	°C
Compensated temperature range	-10...+45	°C
Service temperature range	-25...+70	°C
Storage temperature range	-50...+85	°C
Temperature coefficient of the sensitivity	< ± 0.1	% F.S.* / 10°C
Temperature coefficient of zero signal	< ± 0.1	% F.S.* / 10°C
Zero balance	± 0.02	mV/V
Nominal sensitivity	1	mV/V
Input resistance	352 ± 2	ohm(s)
Output resistance	352 ± 2	ohm(s)
Insulation resistance (50 V)	> 5000	Mohm(s)
Reference excitation voltage	10	VDC
Permissible nominal range of excitation voltage	3...12	VDC
Safe load limit	120	% F.S.*
Breaking load	>250	% F.S.*
Permissible dynamic loading	50	% F.S.*
Static lateral force limit	100	% F.S.*

\* F.S. : Full Scale.

Specifications subject to change without notice.

2625-2645 > STANDARD DIMENSIONS

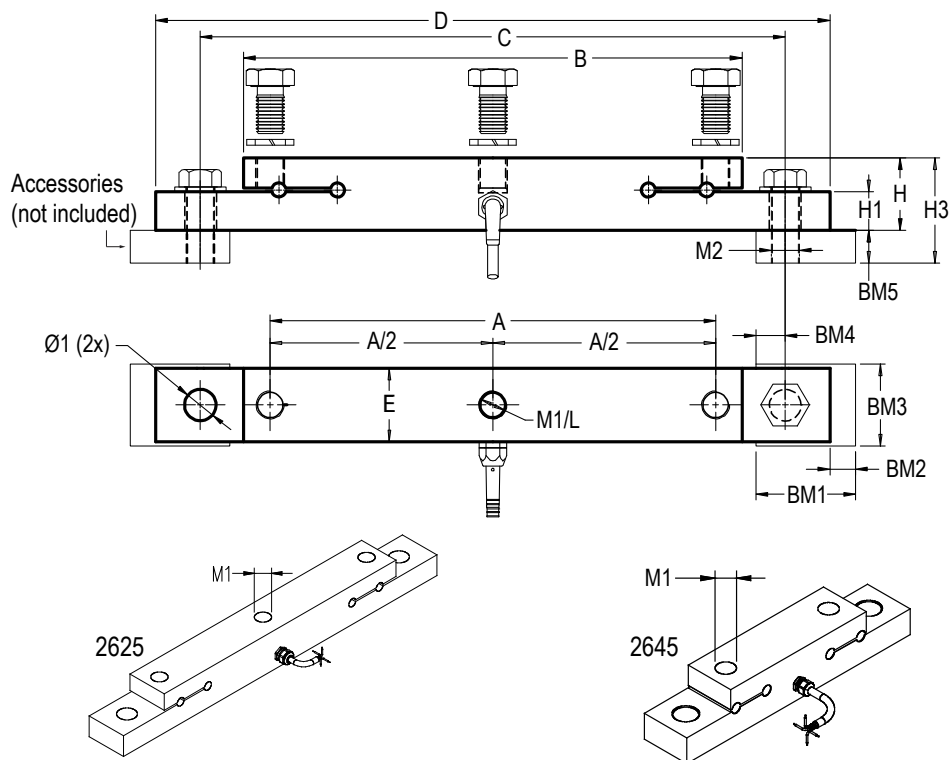

Ref. Item	Capacities		A	B	C	D	E	H	H1	H3	Ø1	M1 / L	CL (m)	Weight (kg)
	Static	Dynamic												
2625-A	10 t	5 t	380	425	499	575	63	62	33	90	27	3xM24x1.5/26	10	14.8
2645-A	10 t	5 t	152	200	270	330	63	62	33	90	27	2xM24x1.5/26	10	7.5
2645-B	50 t	30 t	150	250	510	600	97	97	53	147	38.5	2xM36x3/42	10	31.2

→ Other capacities and dimensions available on request

Dimensions in mm

Accessories										
Ref. Item	BM1	BM2	BM3	BM4	BM5	M2	S1 (DIN 961)	S2 (DIN 961)	W1 (DIN 127)	Weight (kg)
K-BM2625-A	85	22	70	25	28	M24x1.5	3x M24x1.5 L40 10.9	2xM24x1.5 L60 10.9	5x A24	4
K-BM2645-A	85	22	70	25	28	M24x1.5	2x M24x1.5 L40 10.9	2xM24x1.5 L60 10.9	4x A24	3.75
K-BM2645-B	145	50	97	50	50	M36x3	2x M36x3 L70 10.9	2xM36x3 L100 10.9	4x A36	15.3

Wiring

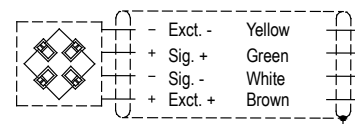

Standard: Cable screen not connected to the transducer

Accessories kit mounting blocks:

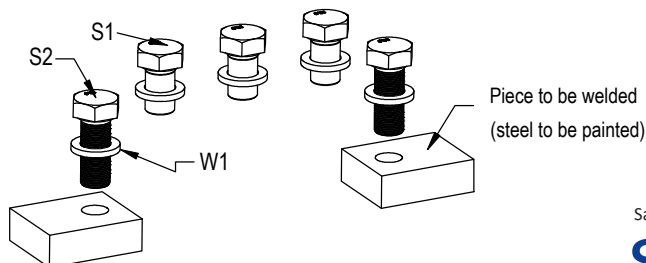

Load direction

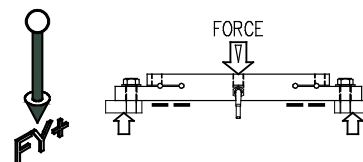

Sales rep.:



Sensors AS  
Setersletta 3  
NO-2006 LØVENSTAD  
+47 67 90 43 00  
post@sensors.no  
www.sensors.no