

# 3100P

## PENDULAR COMPRESSION LOAD CELLS

Compression load cells



Model 3100P - 20 t



### Features

- o Canister, high-capacity load cell (up to 500 t)
- o Made completely of stainless steel
- o Protection class: IP67
- o Pendular technology - Self-restoring
- o Available in C1.5 (1500 d) OIML / R 60 (EN 45501)
- o Matched impedance and sensitivity (for parallel connection)
- o Whole range of mounting accessories is available
- o Cable length: 12 m (500 t: 20 m) (other lengths available on request)

### Most popular options



Ex i



IP68

### Application(s)

SENSY's load cells 3100P are perfectly designed for the following applications:

- Weighbridges, high-capacity reactor weighing,
- Silos, tanks or hoppers weighing.

### Capacities

3100P: (5) - (7.5) - 10 - (15) - 20 - 30 - 50 - (75) - 100 - (150) - 200 - 300 - 500\*\* t

Specifications	0.25 %	0.1 %	C 1.5	0.03 %	
Accuracy class	0.25 % F.S.*	0.1% F.S.*	1500 d OIML	0.03% F.S.*	-
Combined error (non-linearity + hysteresis)	<± 0.25	< ± 0.1	<± 0.035	<± 0.03	% F.S.*
Repeatability error	<± 0.1	<± 0.03	<± 0.015	<± 0.015	% F.S.*
Creep error over 30 min.	<± 0.1	<± 0.06	<± 0.035	<± 0.025	% F.S.*
Reference temperature	23	23	23	23	°C
Compensated temperature range	-10...+45	-10...+45	-10...+45	-10...+45	°C
Service temperature range	-30...+70	-30...+70	-30...+70	-30...+70	°C
Storage temperature range	-50...+85	-50...+85	-50...+85	-50...+85	°C
Temperature coefficient of the sensitivity	<± 0.05	<± 0.05	<± 0.017	<± 0.015	% F.S./10°C
Temperature coefficient of zero signal	<± 0.035	<± 0.035	<± 0.025	<± 0.023	% F.S./10°C
Nominal sensitivity	1.5	1.5	1.5	1.5	mV/V
Sensitivity tolerance	<± 0.3	<± 0.3	<± 0.2	<± 0.2	%
Input resistance	350..700 ± 2	350..700 ± 2	350..700 ± 2	350..700 ± 2	ohm(s)
Output resistance	350..700 ± 2	350..700 ± 2	350..700 ± 2	350..700 ± 2	ohm(s)
Insulation resistance (50 V)	> 5000	> 5000	> 5000	> 5000	Mohm(s)
Reference excitation voltage	10	10	10	10	VDC
Permissible nominal range of excitation voltage	3...12	3...12	3...12	3...12	VDC
Safe load limit	150	150	150	150	% F.S.*
Breaking load	>300	>300	>300	>300	% F.S.*
Permissible dynamic loading	50	50	50	50	% F.S.*
Static lateral force limit	15	15	15	15	% F.S.*

\* F.S. : Full Scale.

\*\* : 2 mV/V

Note: C 1.5 only available for capacities between 5 and 100 t.

Specifications subject to change without notice.

3100P > STANDARD DIMENSIONS

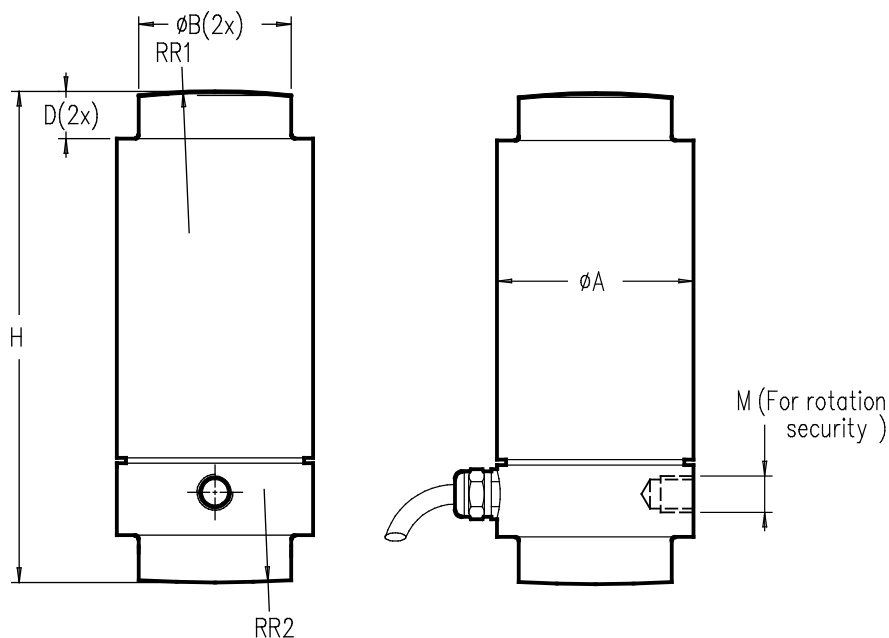

Ref. Item	Capacities	$\varnothing A$	$\varnothing B$	D	H	M	RR1	RR2	H1	H2	Max. Deflexion (mm)	Weight (kg)
3100P-A	5 - 30 t	54	42	13	135	M10	200	250	165	205	0.03 - 0.1	2.2
3100P-B	50 - 100 t	$\pm 89$	64	30	190	M12	300	300	234	294	0.26 - 0.34	5
3100P-C	150 - 200 t	115	90	20	210	M16	400	400	290	370	0.33	15
3100P-D	300 t	136	110	20	240	M16	400	400	338	418	0.4	23
3100P-E	500 t	180	130	25	350	M12	600	600	610	594	0.57	46

→ Other capacities and dimensions available on request

Dimensions in mm

Accessories

Wiring code

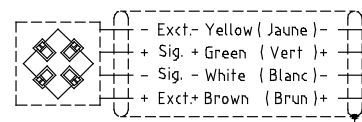
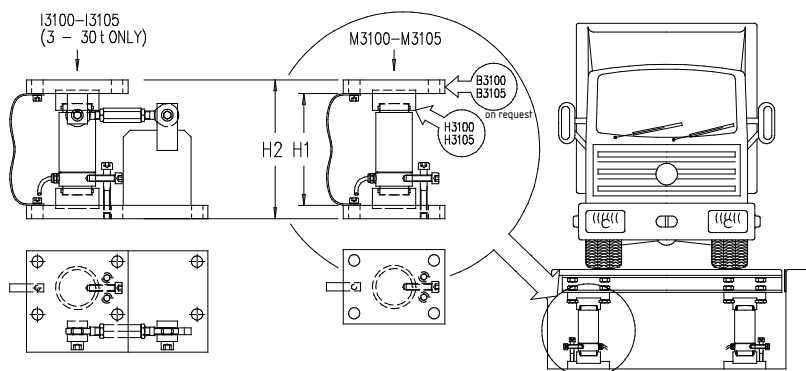

Standard : Cable screen not connected to transducer  
 Faradisation non connectée au capteur

Load direction

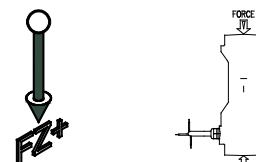

H3100P > STANDARD DIMENSIONS

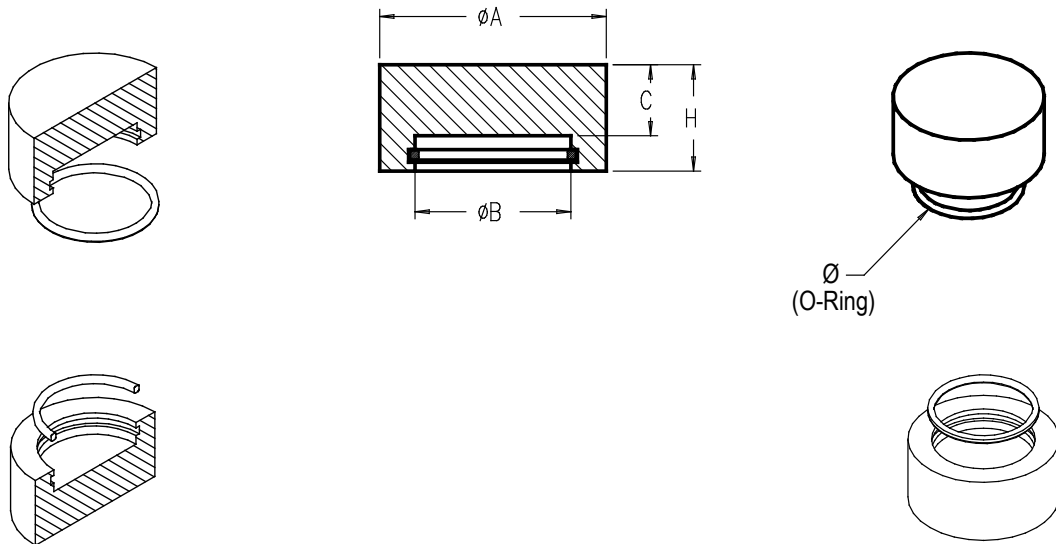

Ref. Item*	Capacities	Ø A	Ø B	C	H	Ø (O-Ring)	Weight (kg)
H3100P-A	5 - 30 t	64	44	20	30	42 x 3	±0.65
H3100P-B	50 - 100 t	99	66	32	43	64 x 4	±2.3
H3100P-C	150 - 200 t	128	92	50	65	90 x 5	±6
H3100P-D	300 t	148	112	59	75	110 x 5	±9
H3100P-E	500 t	178	132	90	105	130 x 5	±19.3

\*Material: stainless steel

→ Other capacities and dimensions available on request

Dimensions in mm

Other view

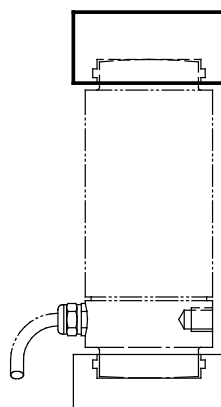

I3100P-I3105P > STANDARD DIMENSIONS

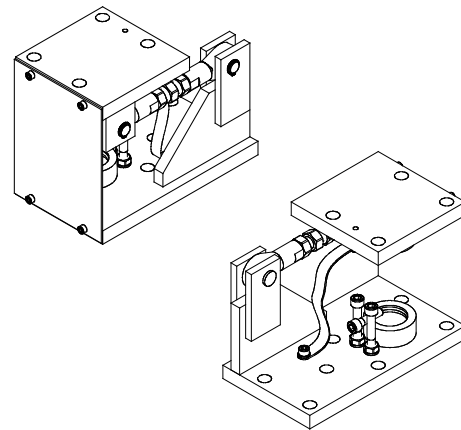
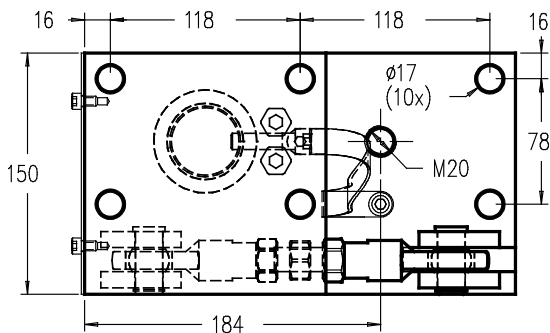
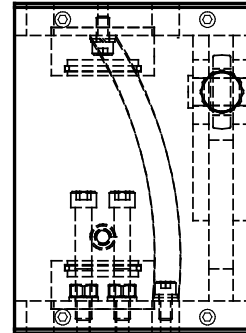
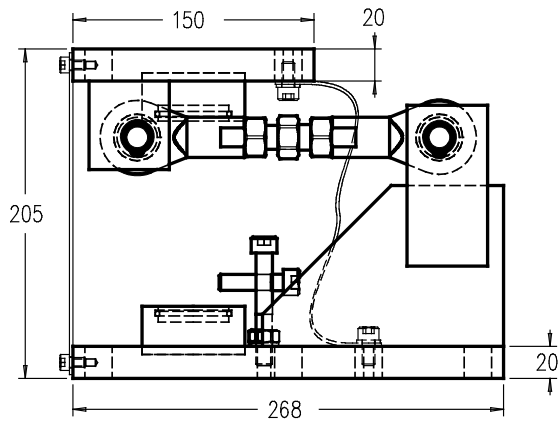

Ref. Item*	Capacities
I310xP-A	5 - 30 t
* x=Material: I3100P - stainless steel; I3105P - alloy steel	

→ Other capacities and dimensions available on request

Dimensions in mm

Other views

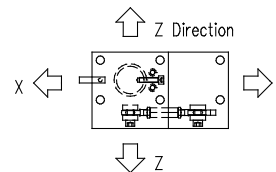
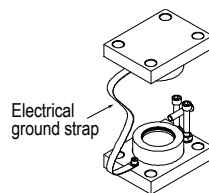
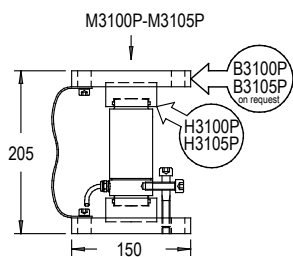

X Direction  
(MAX. 5200 kg STAT.  
2240 kg DYN.)

Stainless steel  
(MAX. 2100 kg STAT.  
800 kg DYN.)

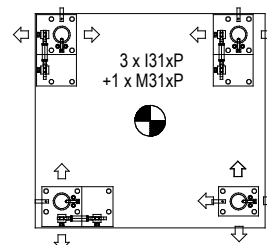
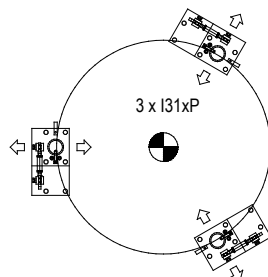
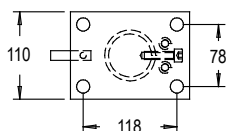

M3100P-M3105P > STANDARD DIMENSIONS

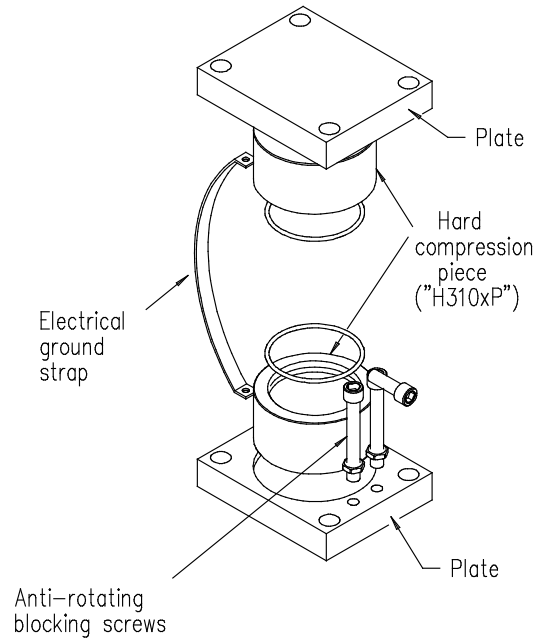
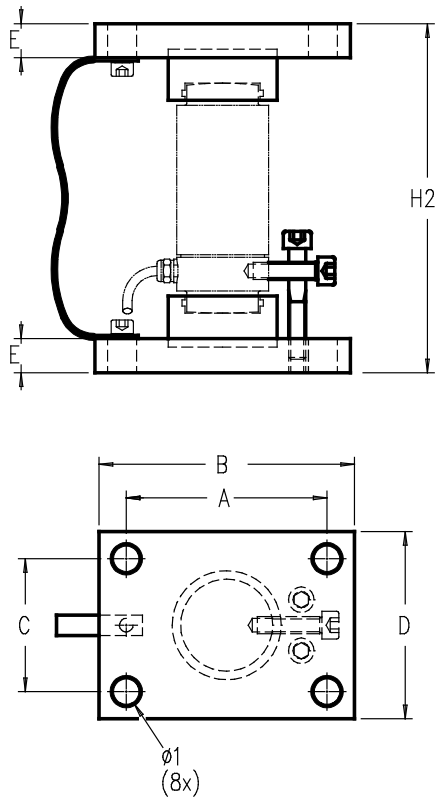

Ref. Items	Capacities	A	B	C	D	E	Ø1	H2	Weight (kg)
M310xP-A	5 - 30 t	118	150	78	110	20	17	205	±5.7
M310xP-B	50 - 100 t	130	170	90	130	30	21	294	±13
M310xP-C	150 - 200 t	185	235	135	185	40	25	370	±35.5
M310xP-D	300 t	185	235	135	185	40	25	418	±41
M310xP-E	500 t	200	260	200	260	40	27	594	±78

\*x=Material: M3100P - stainless steel; M3105P - alloy steel

→ Other capacities and dimensions available on request

Dimensions in mm

Other view

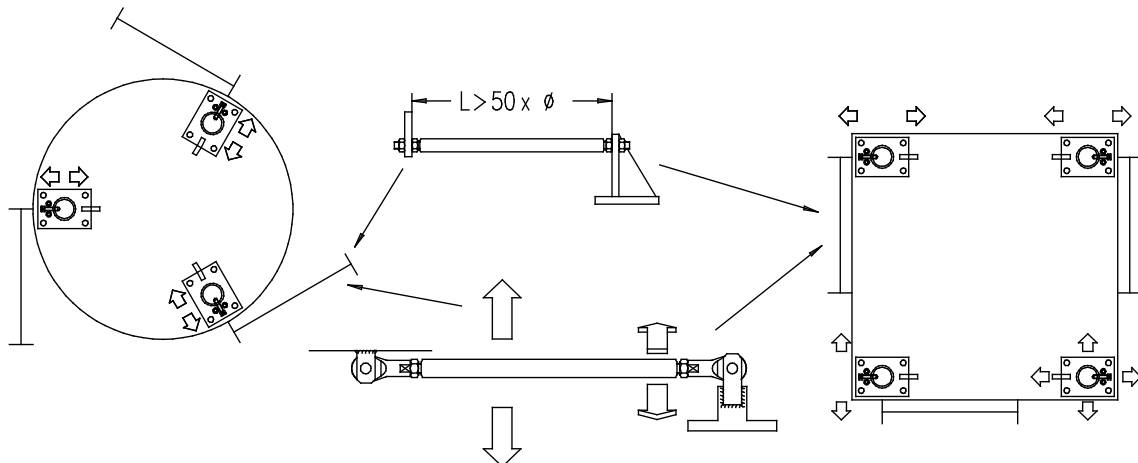

Sales rep.: