

Load cells specially designed to measure the tension force applied to a running cable or running rope.



Model 5575 - 0.5 t



Features

- o Custom-made design according to your needs:
 - type of rope (steel, synthetic, optical fiber, umbilical)
 - capacity
 - rope diameter (from 6 up to 115 mm)
 - maximum winding speed
 - accuracy
- o Protection class: IP65
- o Material:
 - load pin: stainless steel
 - other: nickel-plated steel or stainless steel (option)
- o Complete range of CE certified electronics and load limitation devices available
- o Cable length: 6 m (other lengths available on request)

Most popular options



Application(s) SENSY's load cells 5570-5575 are perfectly designed for the following applications:

- Mooring control in oil and gas and marine equipment,
- Single rope crane load limitation,
- Tension measurement of towage and haulage ropes,
- Winch force measurement.

Capacities

5570 - 5575: from 0.4 to 40 t (up to 600 t on request)

Specifications	2 - 5 %	
Reference temperature	23	°C
Compensated temperature range	-10...+45	°C
Service temperature range	-25...+70	°C
Storage temperature range	-50...+85	°C
Temperature coefficient of the sensitivity	<± 0.1	% F.S./10°C
Temperature coefficient of zero signal	<± 0.1	% F.S./10°C
Nominal sensitivity	± 1 **	mV/V
Input resistance	350 ± 2	ohm(s)
Output resistance	350 ± 2	ohm(s)
Insulation resistance (50 V)	> 5000	Mohm(s)
Reference excitation voltage	10	VDC
Permissible nominal range of excitation voltage	3...12	VDC
Safe load limit	200	% F.S.*
Breaking load	> 300	% F.S.*
Permissible dynamic loading	70	% F.S.*

* F.S. : Full Scale.

** : can be different (depending on the wire rope).

*** : on request (subject to SENSY analysis).

Combined error depends on rope material and on-site calibration.

Specifications subject to change without notice.



ISO 9001 certified

5570-5575 > STANDARD DIMENSIONS

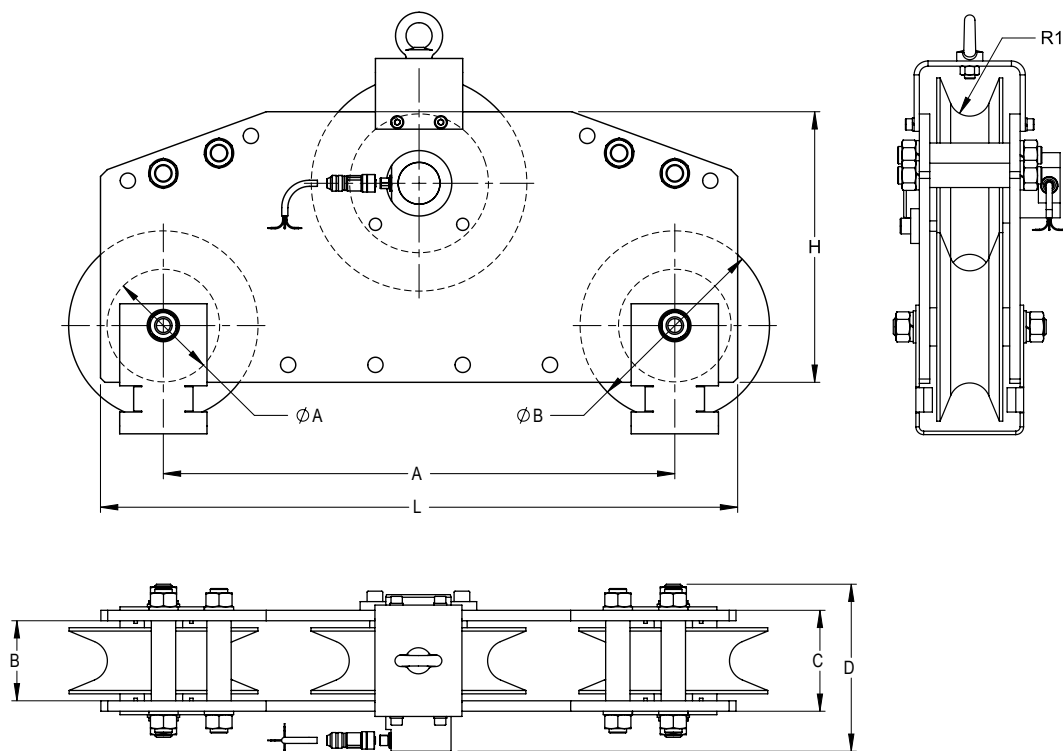

Ref. Item*	Capacities	Ø rope (mm)	ØA	ØB	R1	A	B	C	D	H	L	Max. Speed (m/s)	Weight (kg)
557x-A	400 kg	8	48	90	8.5	500	34	50	110	117	630	1	±9
557x-B	1.5 t	12	48	90	8.5	500	34	50	110	140	630	1	±10.6
557x-C	6 t	16	119	151	9	500	34	50	110	140	661	2	±38
557x-D	20 t	32	120	184	17	900	63	79	159	341	1210	3	±51
557x-E	40 t	36	206	278	19	900	94	122	224	497	1188	4	±224

Ø38 → Ø115 according to customer's design specifications (up to 600 t)

*x=Material: 5570 - stainless steel; 5575 - nickel-plated steel

Configurator: <http://www.sensy.com/tensiometer-configurator/5570-5575>

→ Other capacities and dimensions available on request

Dimensions in mm

Other view

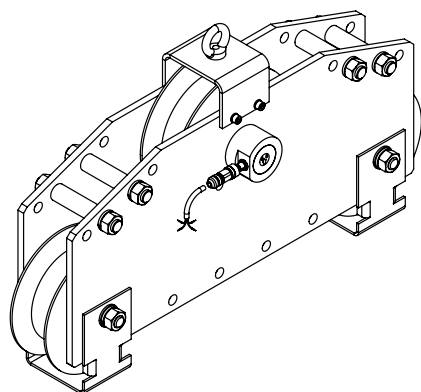

Wiring

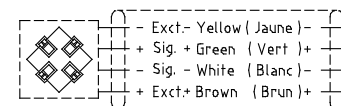

Standard : Cable screen not connected to transducer
Faradisisation non connectée au capteur

Load direction

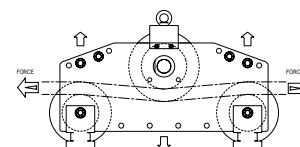

Sales rep.:



Sensors AS
Setersletta 3
NO-2006 LØVENSTAD

+47 67 90 43 00
post@sensors.no
www.sensors.no