

Load cells combining high capacity, low design and cost-effective solution.



Model 5950 - 2 t



Features

- o Material: stainless steel
- o Protection class: IP67
- o Low design
- o Cost-effective solution
- o Sturdy design
- o Easy to install
- o Whole range of mounting kits available
- o Cable length: 8 m (other lengths available on request)

Most popular options



Ex i



-50°C...+150°C

IP68

Application(s) SENSY's load cells 5950 are perfectly designed for the following applications:

- Silos, tanks or hoppers weighing,
- Reactors weighing,
- Industrial force measurement where space is limited.

Capacities

5950: (0.3) - 0.5 - (0.75) - 1 - (1.5) - 2 - 3 - 5 - 7.5 - 10 - 15 - 20** t

Specifications	0.5 %	0.25 %	0.1 %	
Accuracy class	0.5 % F.S.*	0.25 % F.S.*	0.1% F.S.*	-
Combined error (non-linearity + hysteresis)	< ± 0.5	<± 0.25	< ± 0.1	% F.S.*
Repeatability error	< ± 0.25	<± 0.1	<± 0.03	% F.S.*
Creep error over 30 min.	< ± 0.2	<± 0.1	<± 0.06	% F.S.*
Reference temperature	23	23	23	°C
Compensated temperature range	-10...+45	-10...+45	-10...+45	°C
Service temperature range	-25...+70	-25...+70	-25...+70	°C
Storage temperature range	-50...+85	-50...+85	-50...+85	°C
Temperature coefficient of the sensitivity	< ± 0.1	<± 0.05	<± 0.05	% F.S./10°C
Temperature coefficient of zero signal	< ± 0.1	<± 0.035	<± 0.035	% F.S./10°C
Nominal sensitivity	1.5	1.5	1.5	mV/V
Sensitivity tolerance	< ± 0.5	<± 0.3	<± 0.3	%
Input resistance	700 ± 2	700 ± 2	700 ± 2	ohm(s)
Output resistance	700 ± 2	700 ± 2	700 ± 2	ohm(s)
Insulation resistance (50 V)	> 5000	> 5000	> 5000	Mohm(s)
Reference excitation voltage	10	10	10	VDC
Permissible nominal range of excitation voltage	3...12	3...12	3...12	VDC
Safe load limit	150	150	150	% F.S.*
Breaking load	>300	>300	>300	% F.S.*
Permissible dynamic loading	40	40	40	% F.S.*
Static lateral force limit	10	10	10	% F.S.*

* F.S.: Full Scale.

** : 5950-20 t only available with 0.5 % accuracy class

Specifications subject to change without notice..

5950 > STANDARD DIMENSIONS

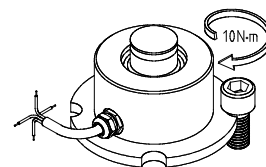
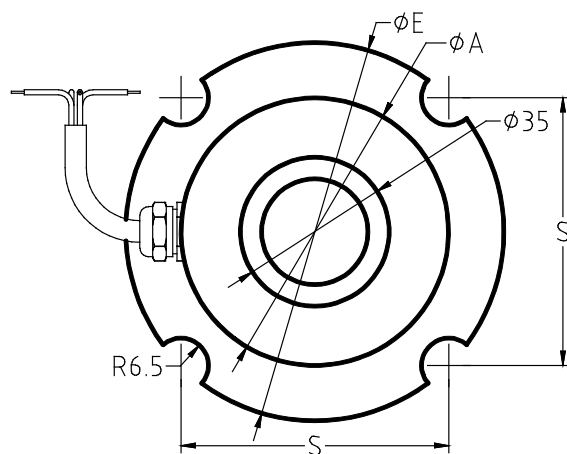
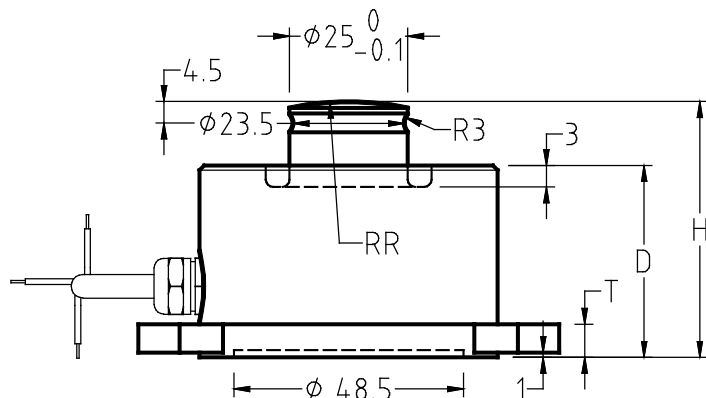

Ref. Item	Capacities	ϕA	D	H	S	T	ϕE	RR	Max. Deflexion (mm)	Weight (kg)
5950-A	0.3 - 5 t	54.5	38.5	54	62.9	7	89	60	0.04 - 0.07	± 1.4
5950-B	7.5 - 15 t	59	38.5	54	62.9	7	89	60	0.08 - 0.15	± 1.4
5950-C	20 t	59	38.5	54	62.9	7	89	60	0.2	± 1.4

Other capacities and dimensions available on request

Dimensions in mm

Accessories

Wiring

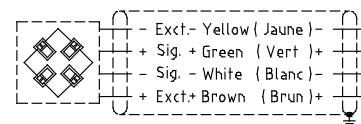
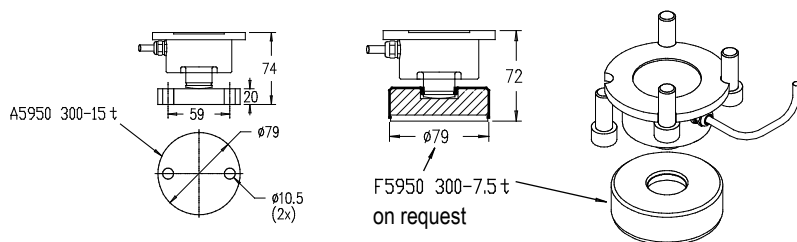

Standard : Cable screen not connected to transducer
Faradisation non connectée au capteur

Load direction

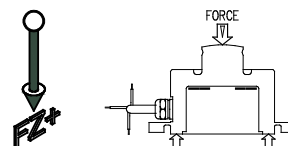

→ A5950 > STANDARD DIMENSIONS

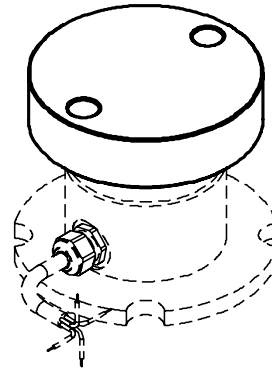
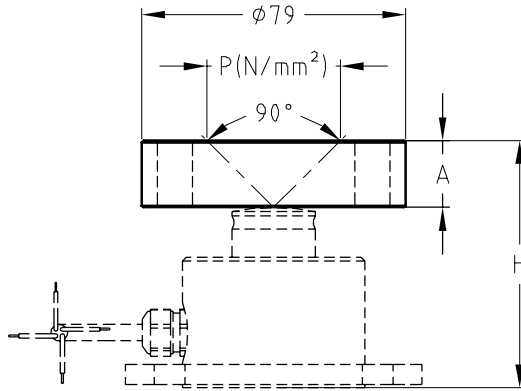

Ref. Item*	Capacities	A	H	P N/mm ²	Weight (kg)
A5950-AB	0.3 - 15 t	20	74	± 120 (15 t)	± 0.76
A5950-C	20 t	25	79	± 100	± 0.95

*Material: stainless steel

→ Other capacities and dimensions available on request

Dimensions in mm

Other view

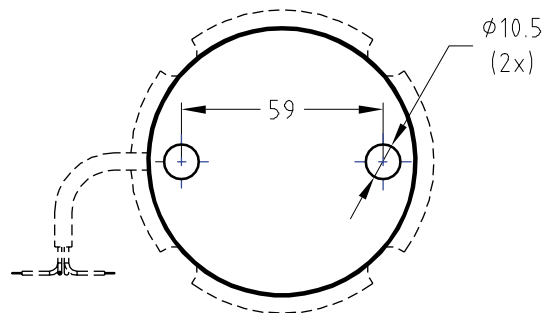

15950-15955 > STANDARD DIMENSIONS

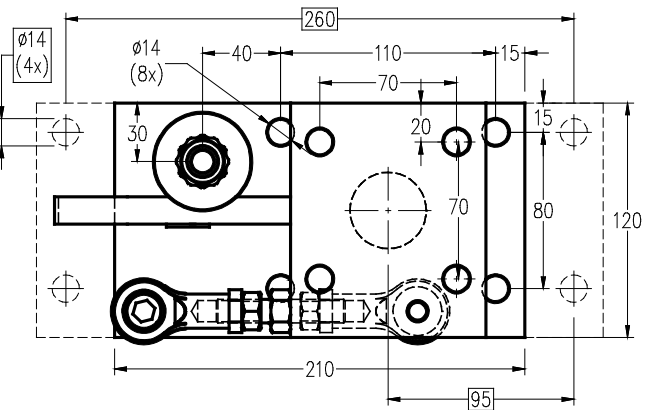
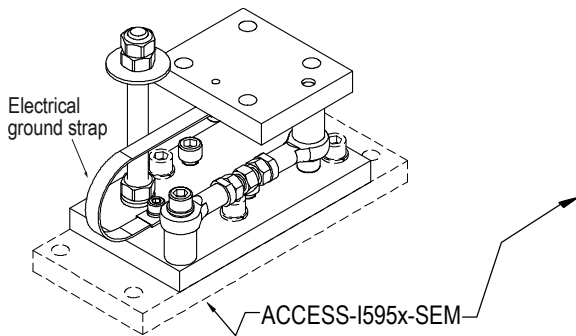
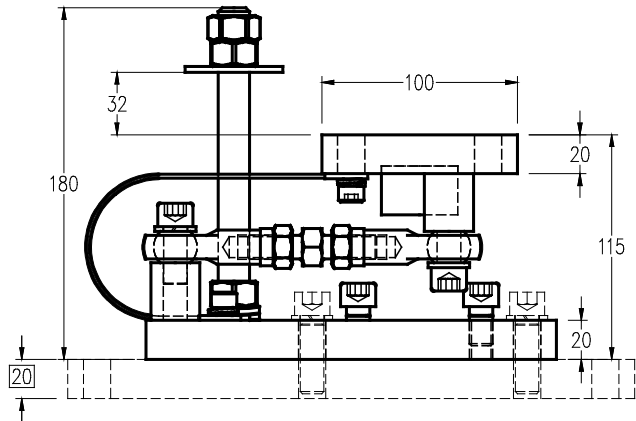
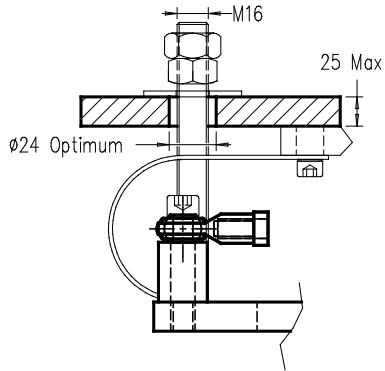

Ref. Item*	Capacities
I595x-A	0.3 - 20 t
*x=Material: I5950 - stainless steel; I5955 - alloy steel	

Other capacities and dimensions available on request

Dimensions in mm

Other views

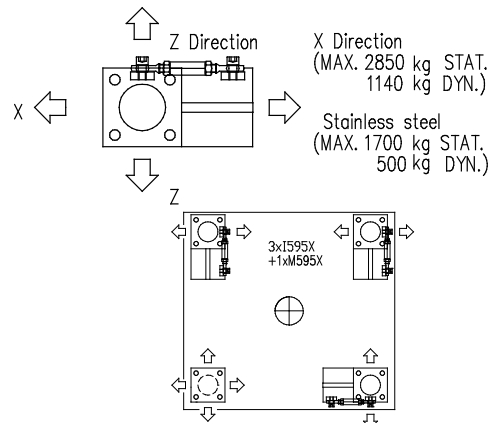
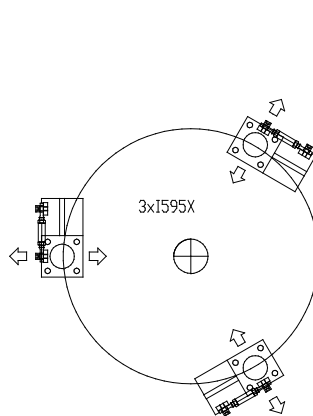
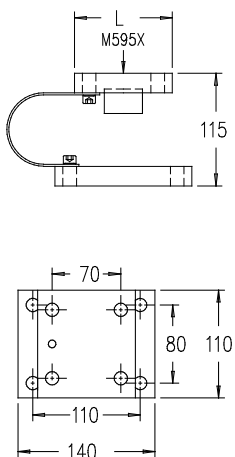

→ M5950 > STANDARD DIMENSIONS

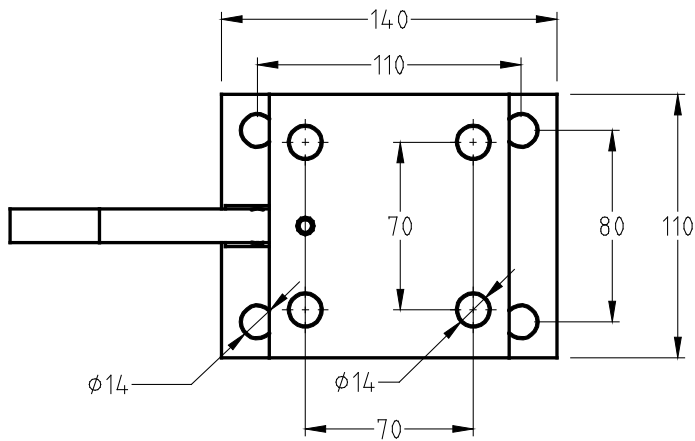
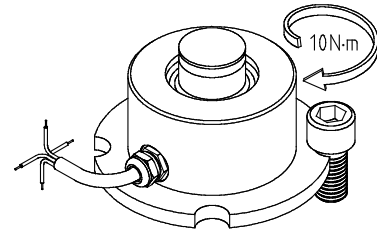
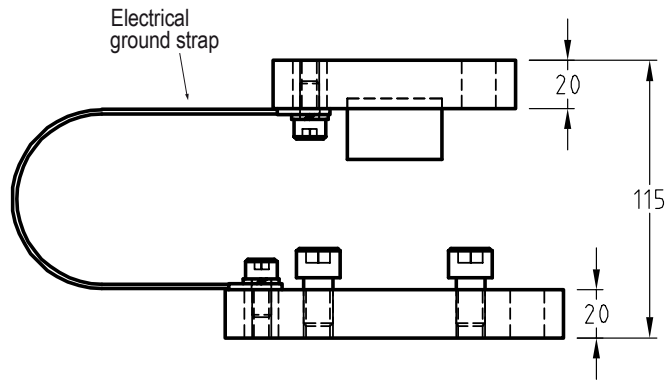

Ref. Item*	Capacities
M595x-A	0.3 - 20 t
*Material: M5950 - stainless steel; M5955 - alloy steel	

→ Other capacities and dimensions available on request

Dimensions in mm

Other view

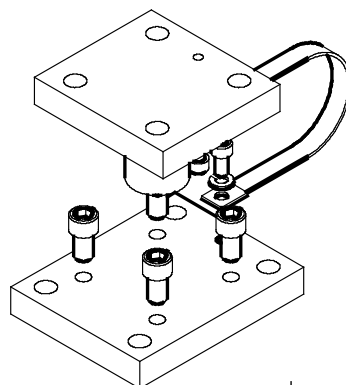

Sales rep.:



Sensors AS
Setersletta 3
NO-2006 LØVENSTAD

+47 67 90 43 00
post@sensors.no
www.sensors.no

Rev. 16/04/2018